

Understanding the Dehumidification Performance of Air-Conditioning Equipment at Part-Load Conditions

Part 2: Test Results

DOE/NETL Project #DE-FC26-01NT41253

Don B. Shirey, III - FSEC

Hugh I. Henderson, Jr. - CDH Energy Corp.

Richard A. Raustad - FSEC



ASHRAE Annual Meeting

July 2, 2003

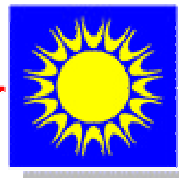

FLORIDA SOLAR ENERGY CENTER

A Research Institute of the University of Central Florida

Project Scope

- ❑ Literature Review
- ❑ **Lab Testing** ←
- ❑ **Field Testing** ←
- ❑ Model Development and Validation

Laboratory Testing

- ❑ Test up to 10 direct expansion (DX) and chilled water coils in various configurations
- ❑ Experimentally determine:
 - off-cycle evaporation rates and decay profile
 - moisture-holding capacity of the cooling coil surfaces
- ❑ Compare measured cycling performance to the latent degradation model

Laboratory Testing Approach

- Each ON/OFF cyclic test completed at various air flows and entering conditions (coil ON/OFF, air flow always ON)
- Typically ON for 45 - 60 minutes, OFF for similar period
- Base tests repeated to get quasi-steady cyclic conditions

| Air Flow | Entering Coil Conditions (db / wb) | | | | | |
|---------------------------------|------------------------------------|------------------------|------------------------|------------------------|------------------------|------------------------|
| | 80 / 67° F 60° F dp | 80 / 72° F 68° F dp | 80 / 62° F 50° F dp | 75 / 68° F 64° F dp | 75 / 63° F 56° F dp | 75 / 60° F 50° F dp |
| 400 cfm / ton | #4 (or 3) | #5 | #6 | #7 | #8 | #9 |
| 300 cfm / ton | #10 | #11 | #12 | #13 | #14 | #15 |
| 200 cfm / ton | #16 | #17 | #18 | #19 | #20 | #21 |
| 450 cfm / ton | #22 | #23 | #24 | | | |
| 400-200 cfm / ton (ON & OFF) | #25 | | | | | |
| Low suction | #1 | | | | | |
| High suction | #2 | | | | | |

Laboratory Test Facility Instrumentation

- ❑ At total of 28 parameters are monitored at 15-second intervals and stored for analysis:
 - Temperature: Air and cooling coil temperatures at various locations using Type-T thermocouples at $\pm 1^{\circ}\text{F}$ (0.6°C)
 - Dew Point: Air dew point entering and leaving the cooling coil using $\pm 0.36^{\circ}\text{F}$ (0.2°C) dew point hygrometers
 - Airflow: Pressure drop across ASME MFC-3M-1984 orifice plate
 - Refrigerant Pressure: Evaporator outlet and liquid line pressures monitored using pressure transducers at 0.013% FS accuracy
 - Condensate: condensate measured using rain-gage tipping bucket at 0.0087 lbs/tip
 - Electrical Consumption: $\pm 0.5\%$ watt-hour transducers

Latent Degradation Concepts

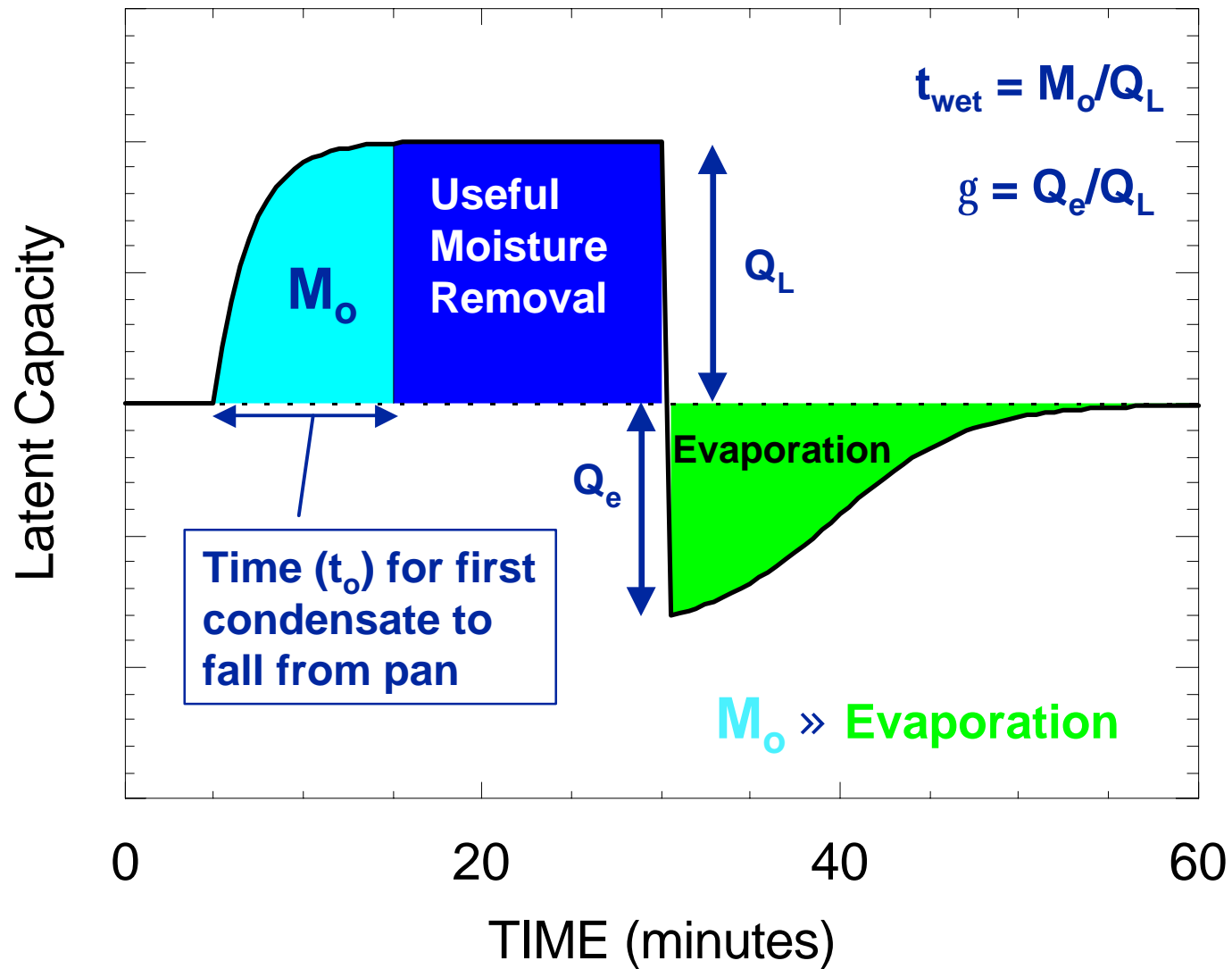

Actual Laboratory Results

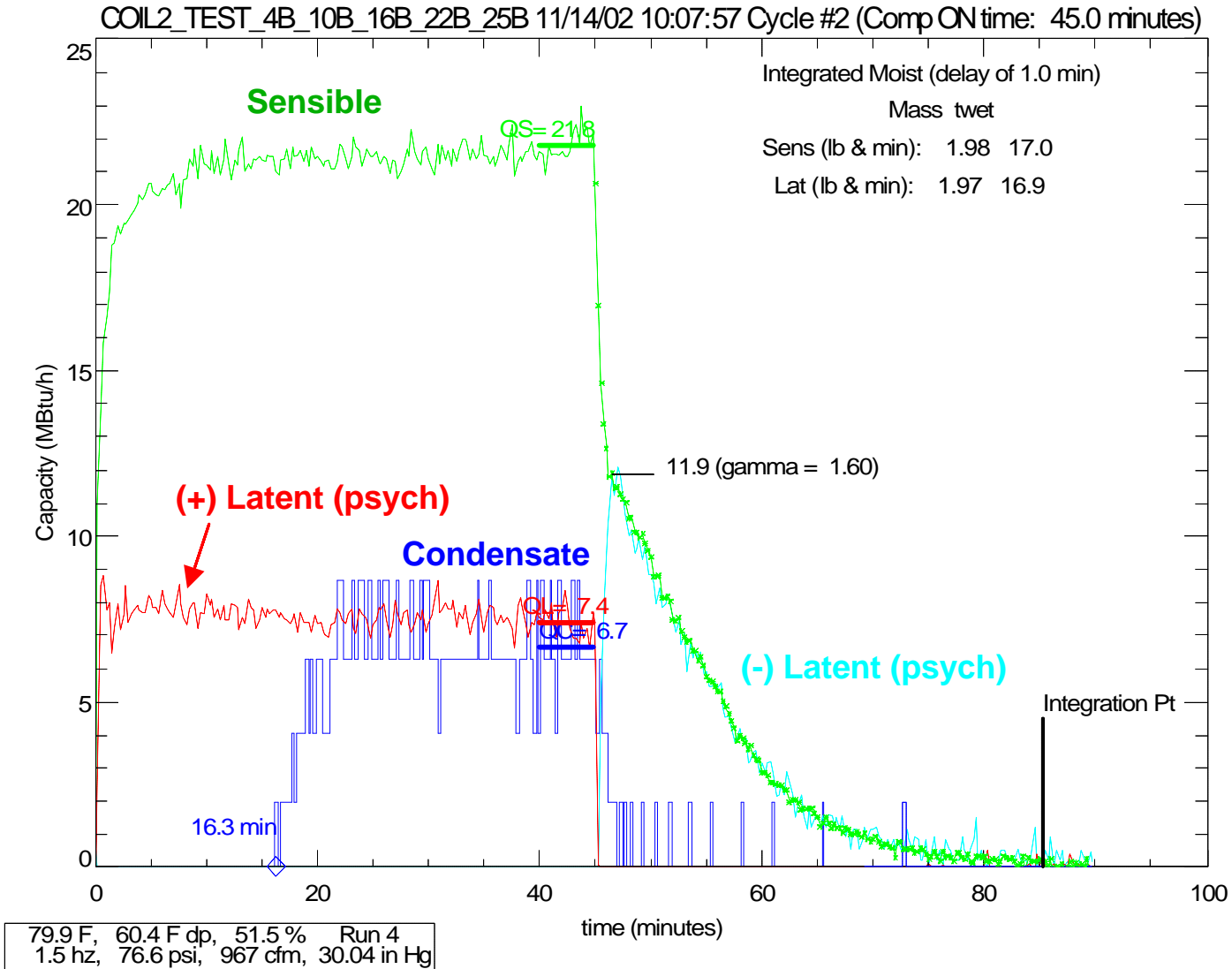

Laboratory Testing – Balance

Several checks of data validity:

- Q-Psych vs. Q-Condensate
- Steady-state trends OK?
- Room conditions maintained over cycle?

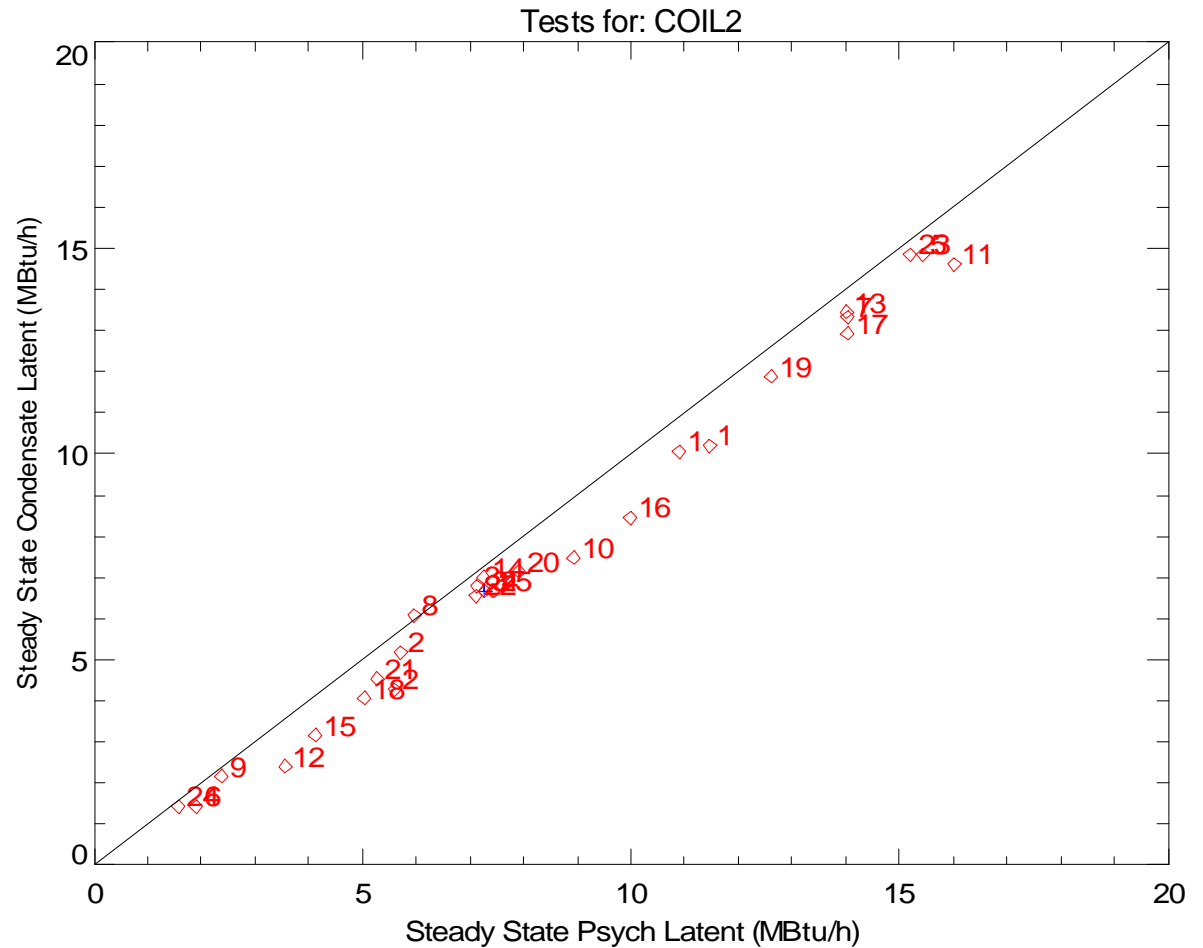

Laboratory Testing – Off Cycle

- The off-cycle evaporation rate (Q_e) follows theoretical trends

(except for #6, #9 & #24)

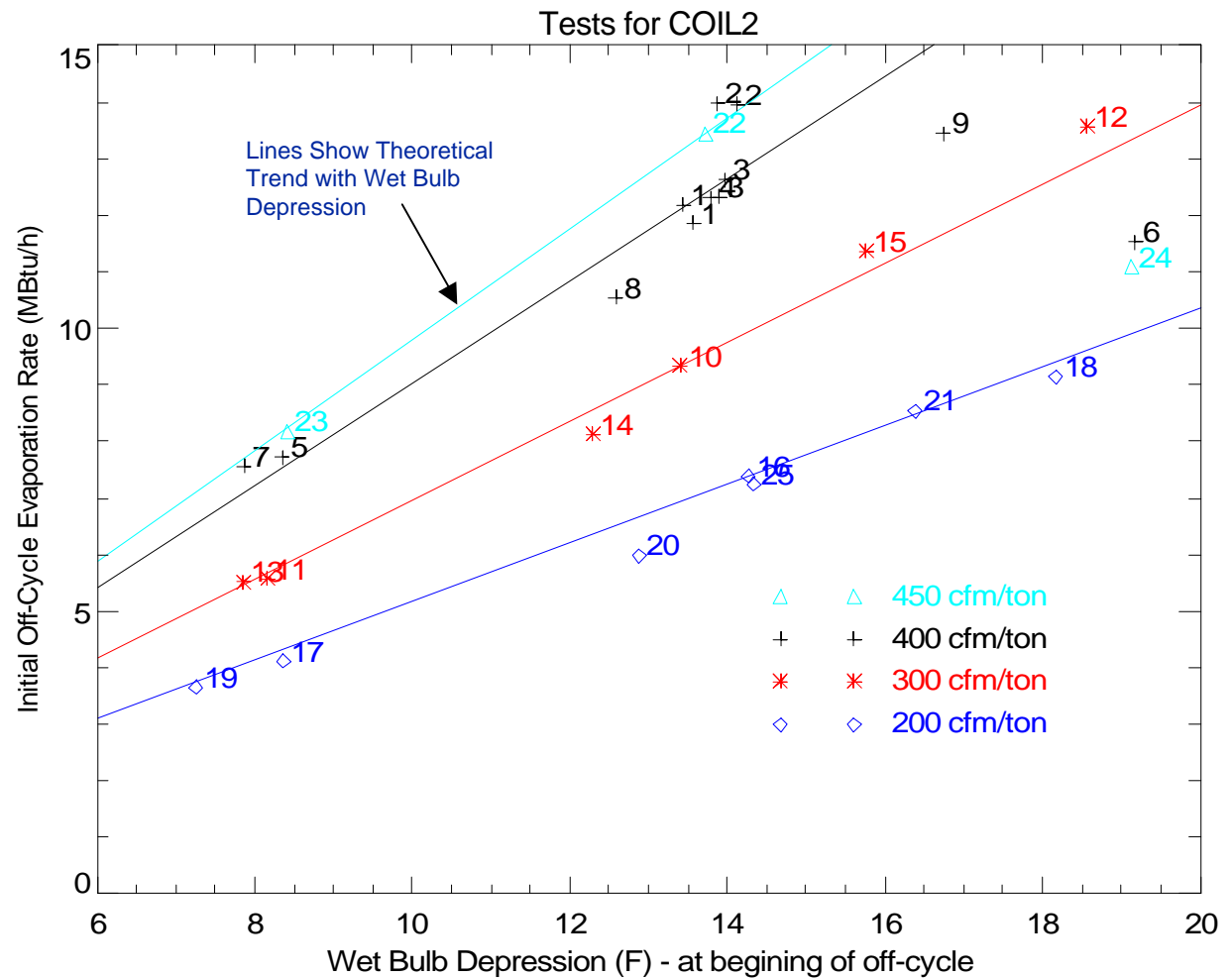

Equipment Survey

- ❑ Reviewed specifications for 500 commercial and residential AC units
- ❑ Goal was to determine
 - range of common coil geometries
 - Variation by equipment type
- ❑ Typical DX AC coil is 3-rows, 15 fpi
- ❑ Some variation by equipment type
- ❑ Some variation by size as well

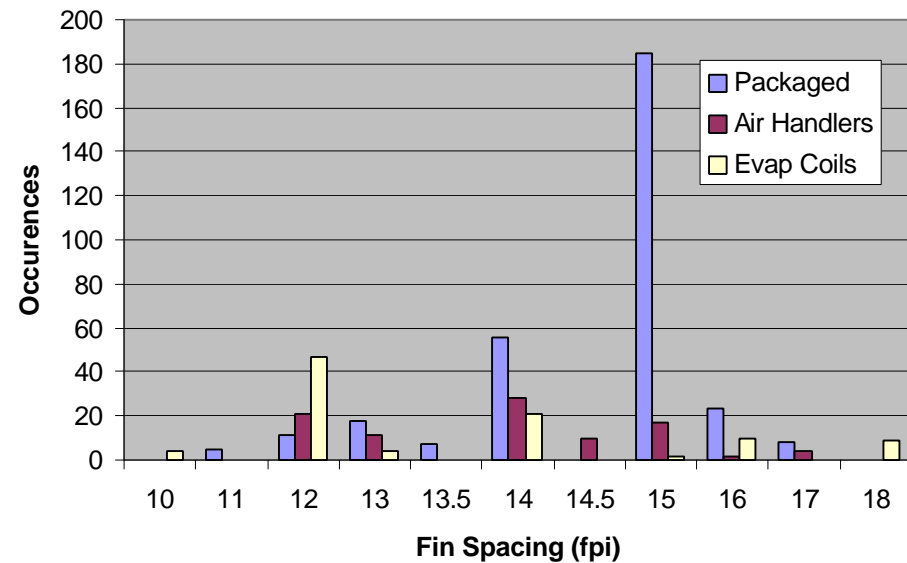
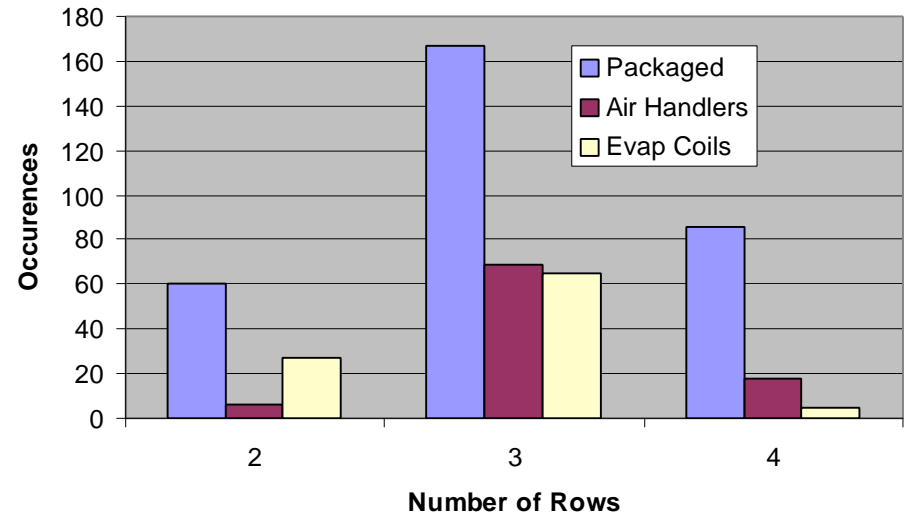

Measured Performance Parameters

| | Cooling Capacity (ton / kW) | Fin Surface Area (ft² / m²) | Retained Moisture Mass (lb / kg) | Condensate Delay Time (min) | t_{wet} (min) |
|---|--|--|---|--|----------------------------------|
| Coil 1 (Slanted slab, 3 row, 13 fpi, plain fins, orifice) | 3.0 / 10.5 | 253.3 / 23.5 | 2.1 / 0.95 | 13.5 | 16.5 |
| Coil 2 – Normal Flow (A-coil, 3 rows, 15.5 fpi, lanced sine-wave fins, TXV) | 2.5 / 8.8 | 237.8 / 22.1 | 2.5 / 1.14 | 16.3 | 19.0 |
| Coil 2 – Low Flow (A-coil, 3 rows, 15.5 fpi, lanced sine-wave fins, TXV) | 1.5 / 5.3 | 237.8 / 22.1 | 2.5 / 1.14 | 33.3 | 35.4 |
| Coil 4 (vert. slab, 2 rows, 14 fpi, wavy fins, orifice) | 1.8 / 6.3 | 138.3 / 12.8 | 1.9 / 0.86 | 23.5 | 18.5 |

- Notes:
- 1- Cooling capacity includes sensible and latent cooling at nominal conditions. Nominal conditions correspond to ASHRAE Test A or ISO T1 test points.
 - 2- Surface area is gross fin area (coil face area x coil depth x fin spacing x 2).
 - 3- Condensate delay time and t_{wet} are at nominal conditions

Laboratory Testing – SHR Degradation

- ❑ Simulated real operating cycles at various runtime fractions (for a given thermostat)
- ❑ Each sequence repeated 3 times to reach quasi-steady state conditions

| CONST FAN | AUTO FAN | Number of Times Test Repeated | ON Time | OFF Time | Runtime Fraction | Cycle Rate |
|------------------|-----------------|--------------------------------------|----------------|-----------------|-------------------------|-------------------|
| Run | | | (minutes) | (minutes) | (-) | (cycles/h) |
| 31 | 41 | 2 | 45 | 45 | 0.500 | 0.667 |
| 32 | 42 | 3 | 30 | 6 | 0.833 | 1.667 |
| 33 | 43 | 3 | 16 | 7.25 | 0.688 | 2.581 |
| 34 | 44 | 3 | 10 | 10 | 0.500 | 3.000 |
| 35 | 45 | 3 | 7 | 17.5 | 0.286 | 2.449 |
| | 46 | 3 | 5.5 | 55 | 0.091 | 0.992 |

Laboratory Testing – SHR Degradation (cont.)

**Model matches
measured data at
nominal entering
conditions
(80F db, 60.4F dp)**

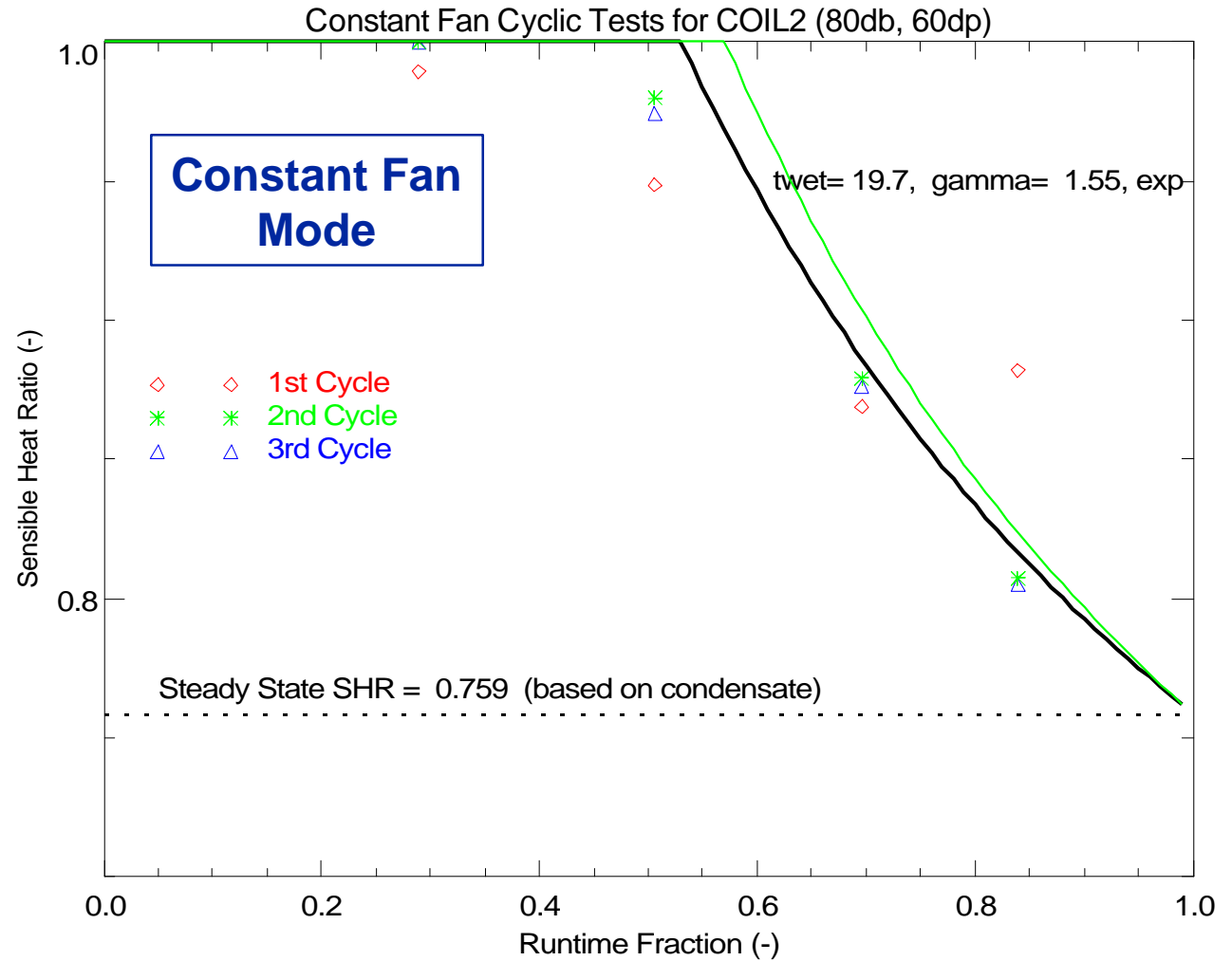

Laboratory Testing – SHR Degradation (cont.)

Model also matched measured data at other entering conditions!
(75F db, 64F dp)

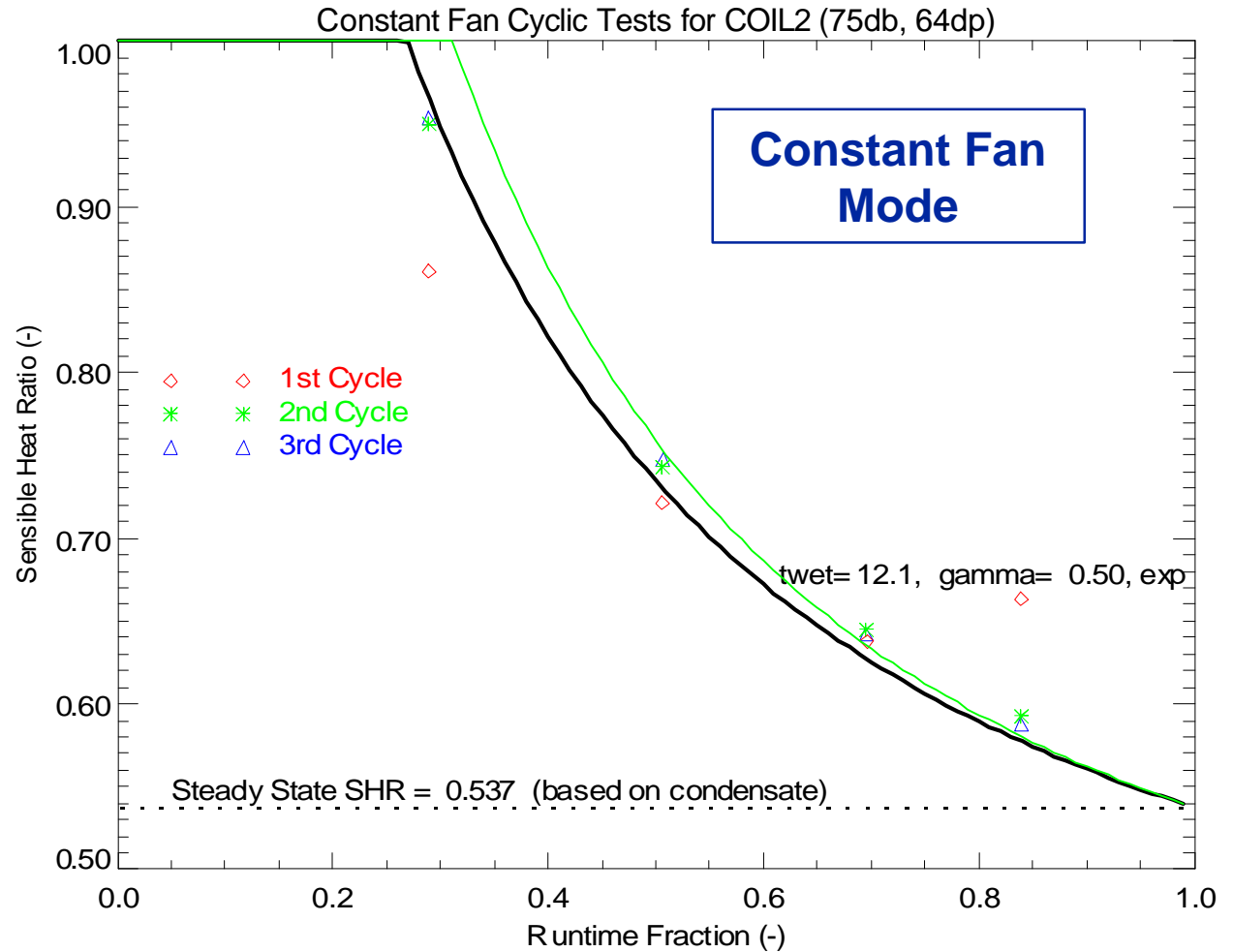

Laboratory Testing – SHR Degradation (cont.)

Model also
matched
measured data
at reduced air
flow rate
(300 cfm / ton)

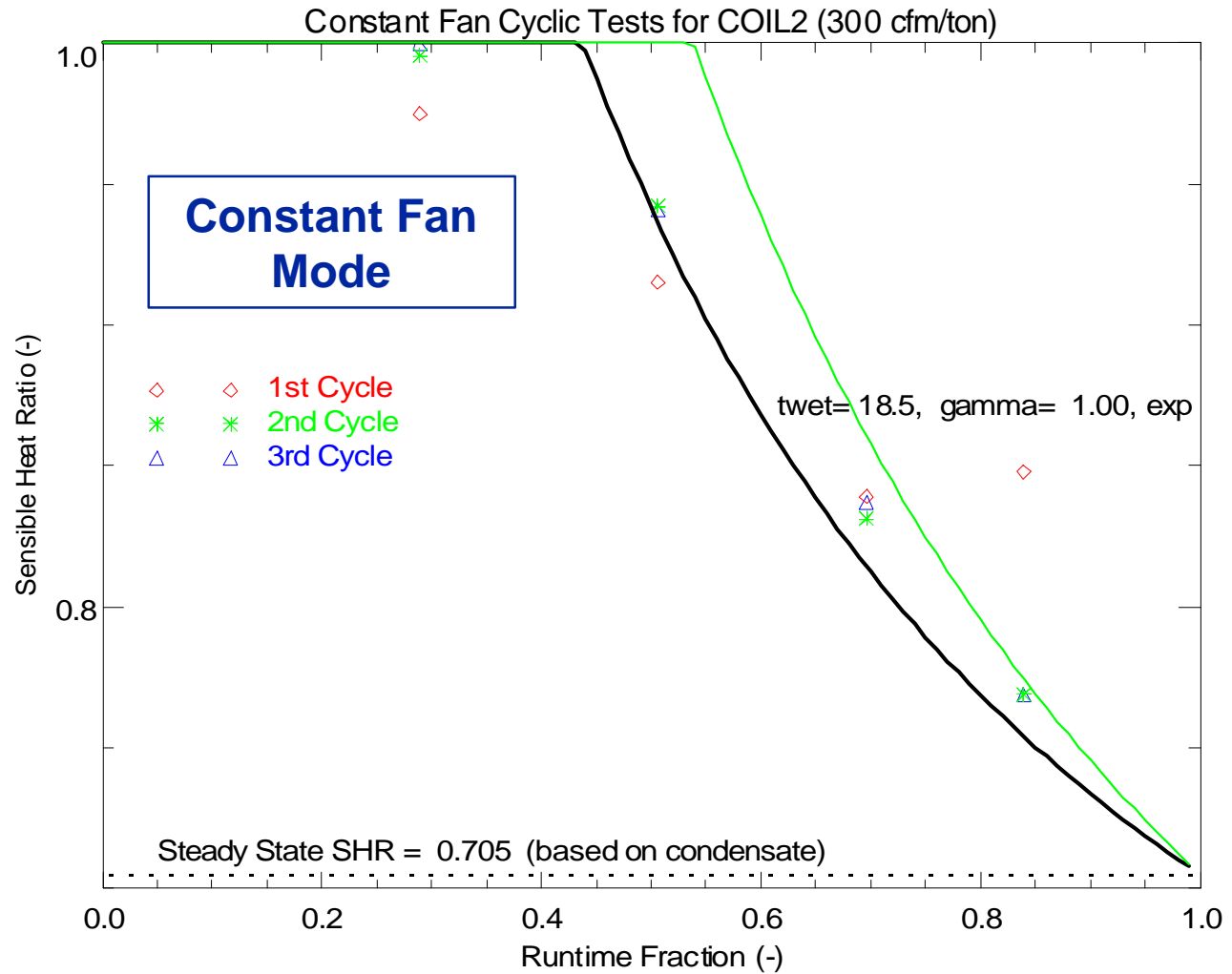

Laboratory Testing – SHR Degradation (cont.)

Coil 2 showed little impact

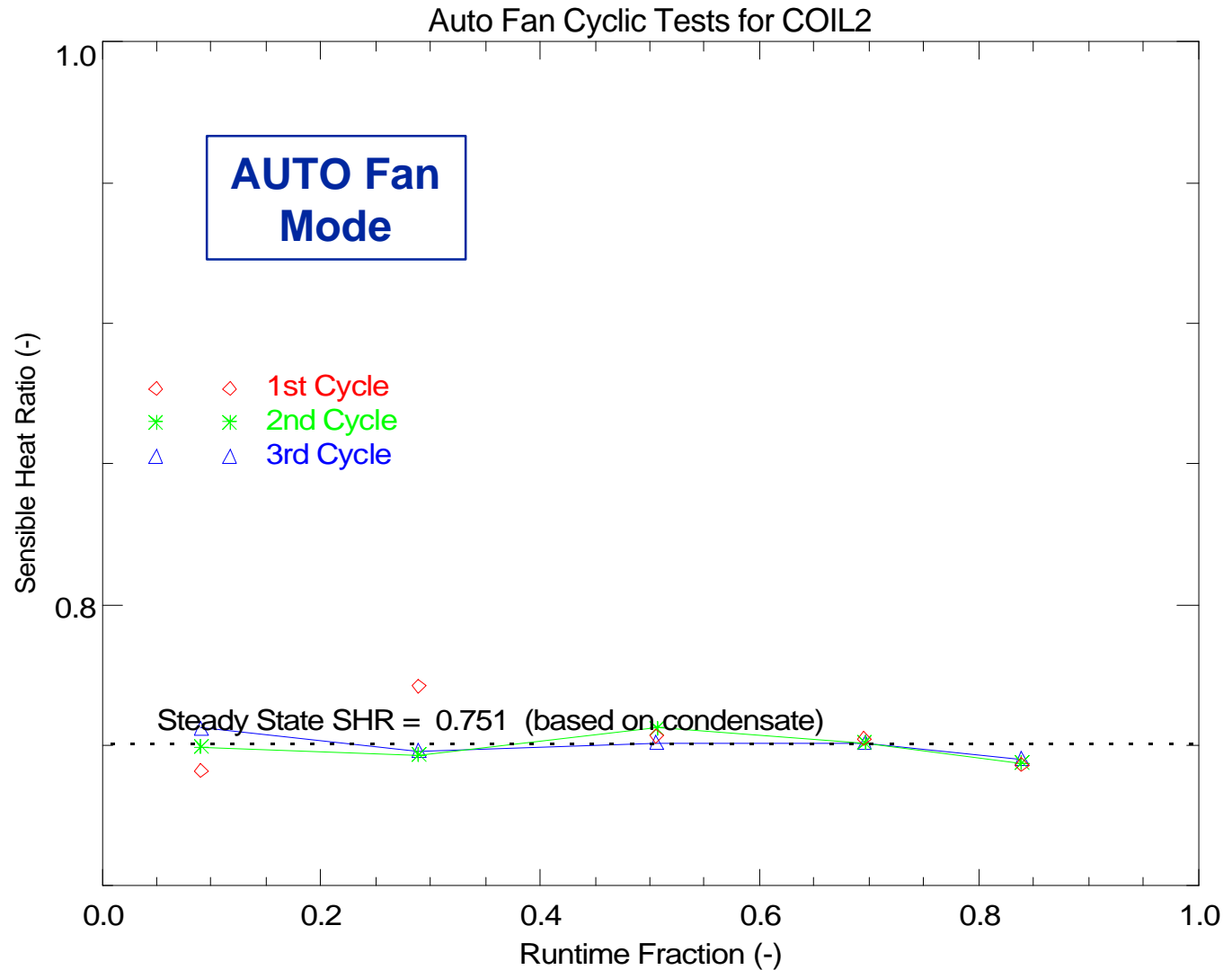

Laboratory Testing – SHR Degradation (cont.)

Coil 1 showed more impact!

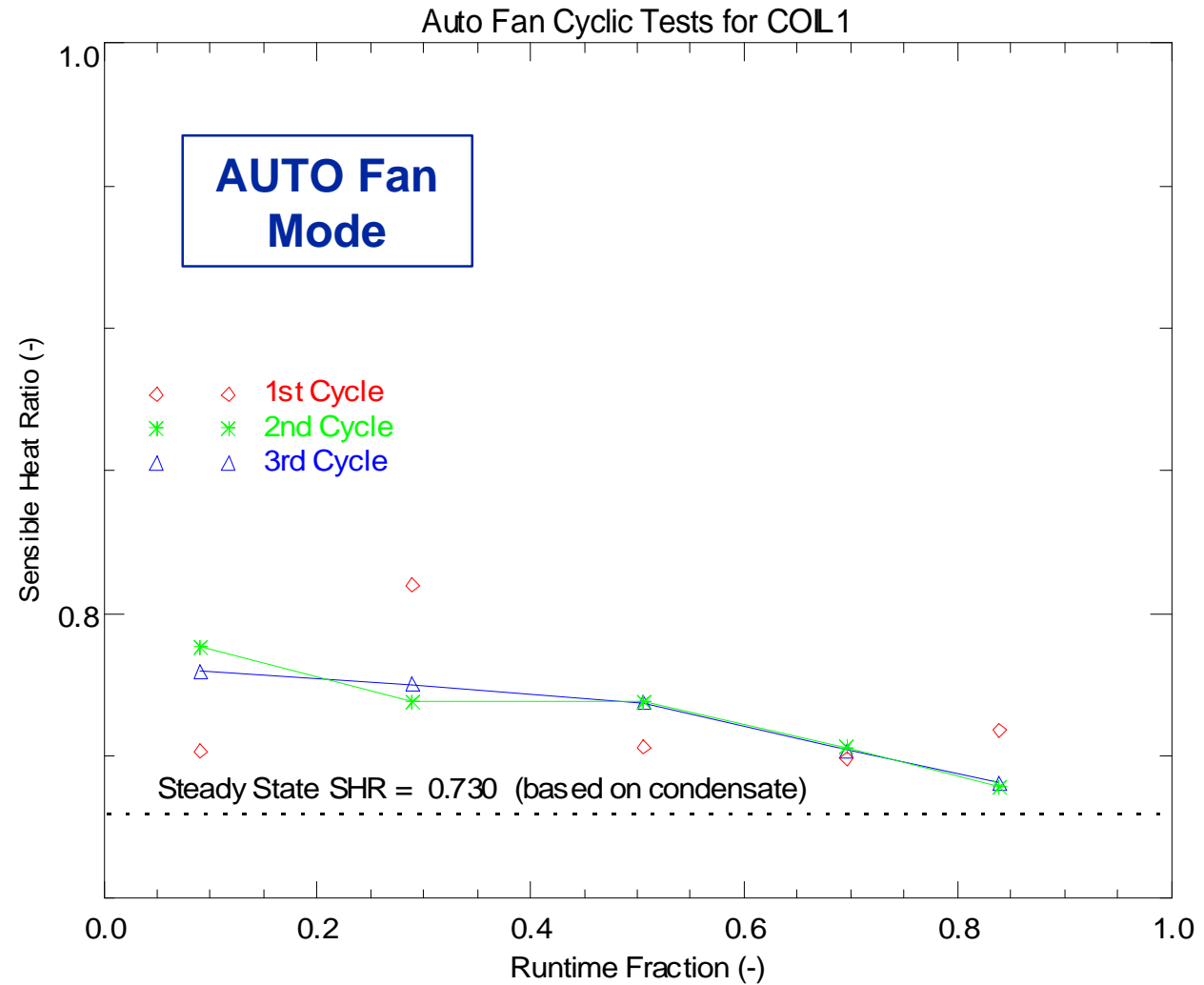

Laboratory Testing – SHR Degradation (cont.)

Coil 4 showed even more impact. Rerunning this test to confirm.

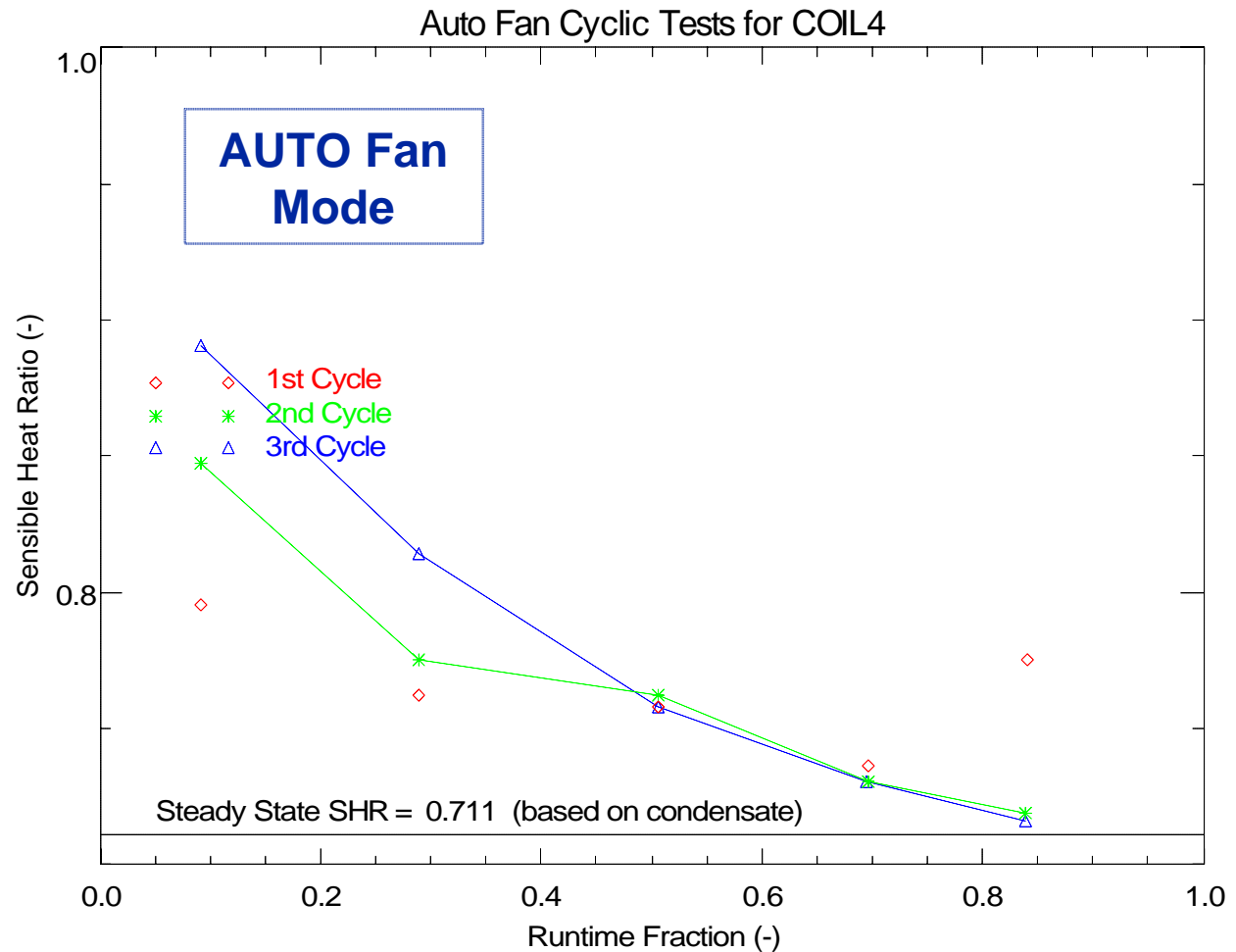

Field Testing

❑ Seven field test sites were recruited:

Residential (5 units at 4 sites)

- 5-ton single-speed residential DX system in Connecticut
- Two single-speed DX units (2.5-ton and 3-ton) at a Virginia residence
- 3.5-ton residential DX system in Florida (single-speed condensing unit with variable speed air handler)
- 3-ton residential DX system in Florida (two-speed condensing unit with variable speed air handler)

Commercial (3 units at 3 sites)

- 10-ton commercial rooftop DX unit in Boston (2 stage)
- Commercial constant-air-volume chilled water coil in Florida (3 ton)
- Commercial variable-air-volume chilled water coil in Florida (7 ton)

Field Testing Approach

- ❑ Collect data on real world system performance
- ❑ Approx. 20 parameters measured on each system, similar to lab points
- ❑ 10-second scans, 1-minute avg or sum stored
- ❑ Daily data download and screening

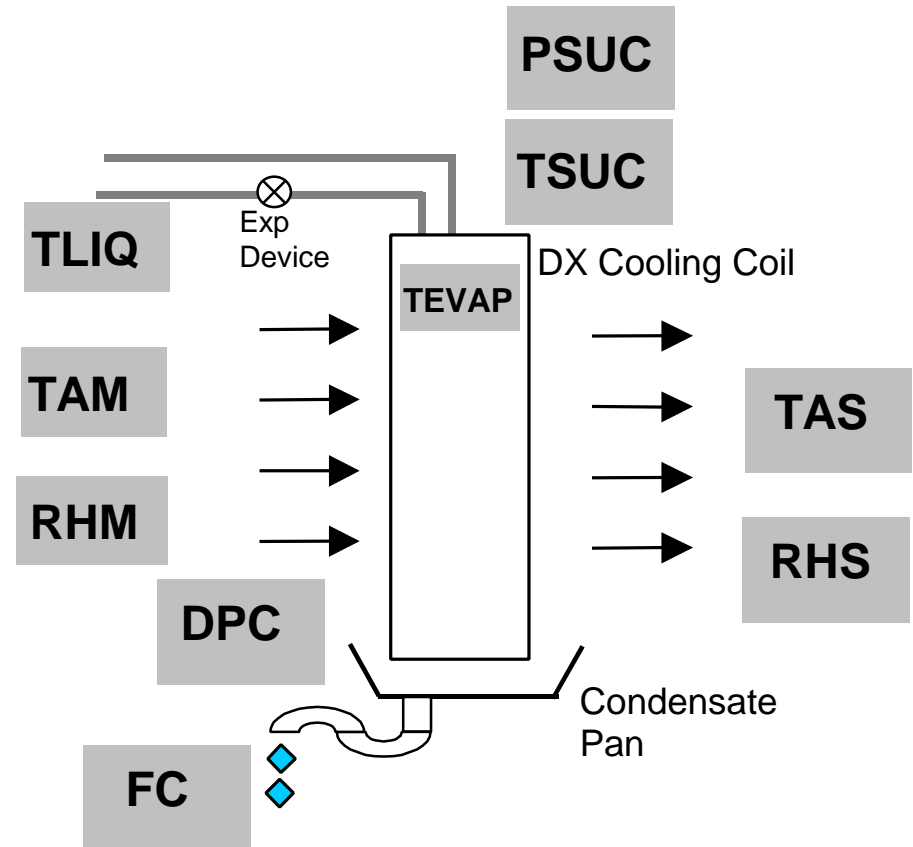

Field Testing – SHR Degradation

Significant
AUTO fan
degradation!

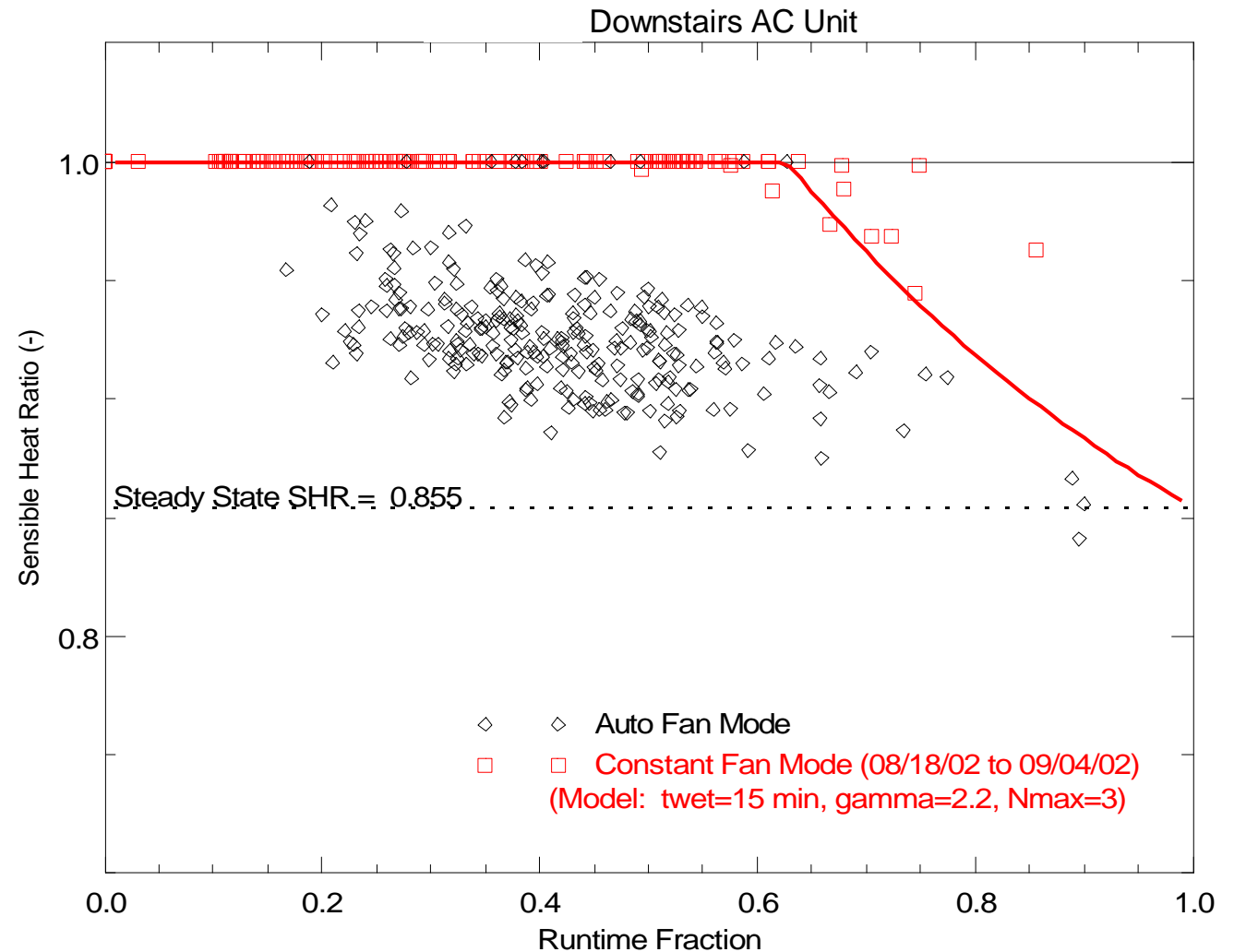

Field Testing – Condensate Delay

- Delay time is good surrogate for t_{wet}
- Must find cycles where coil was dry
- 16 minutes

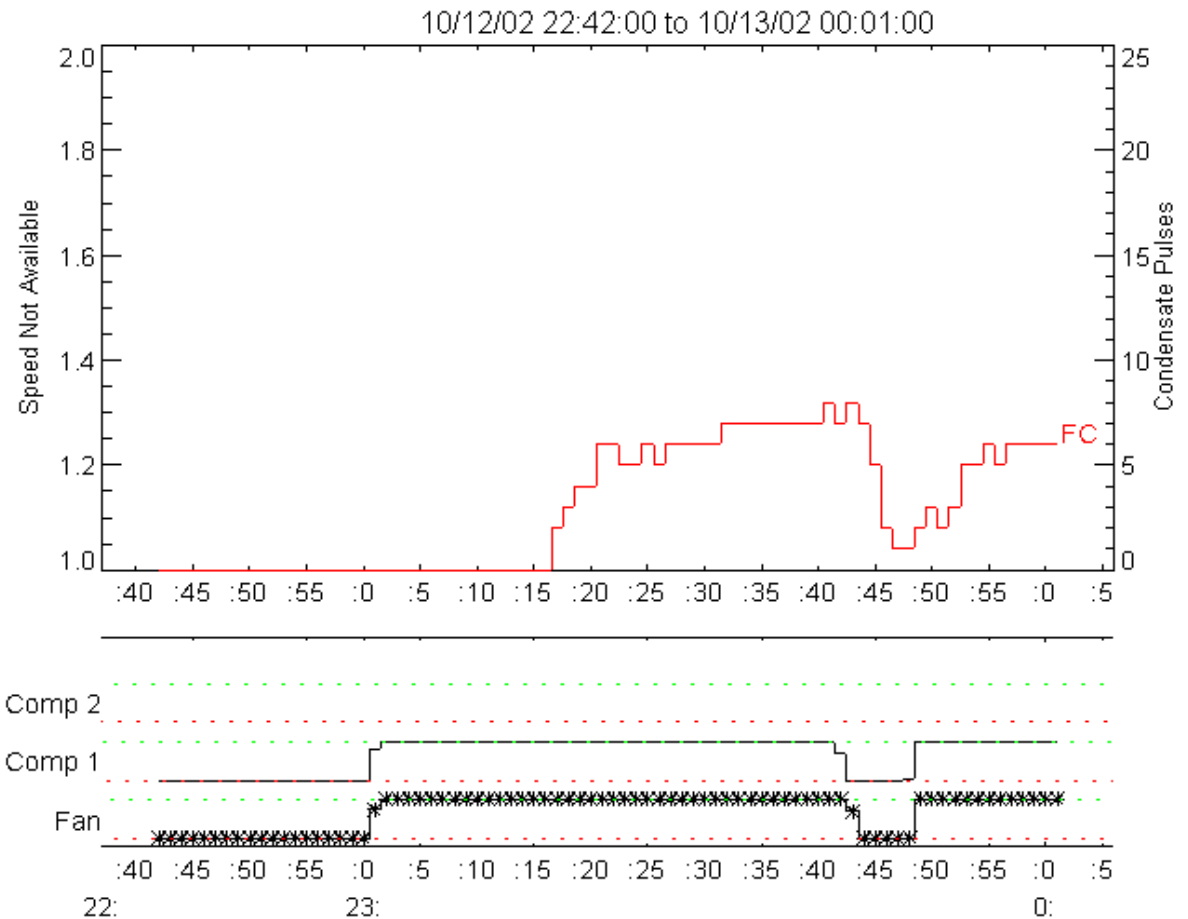

Field Testing – Delay Time Trend

- Delay time a function of entering dew point

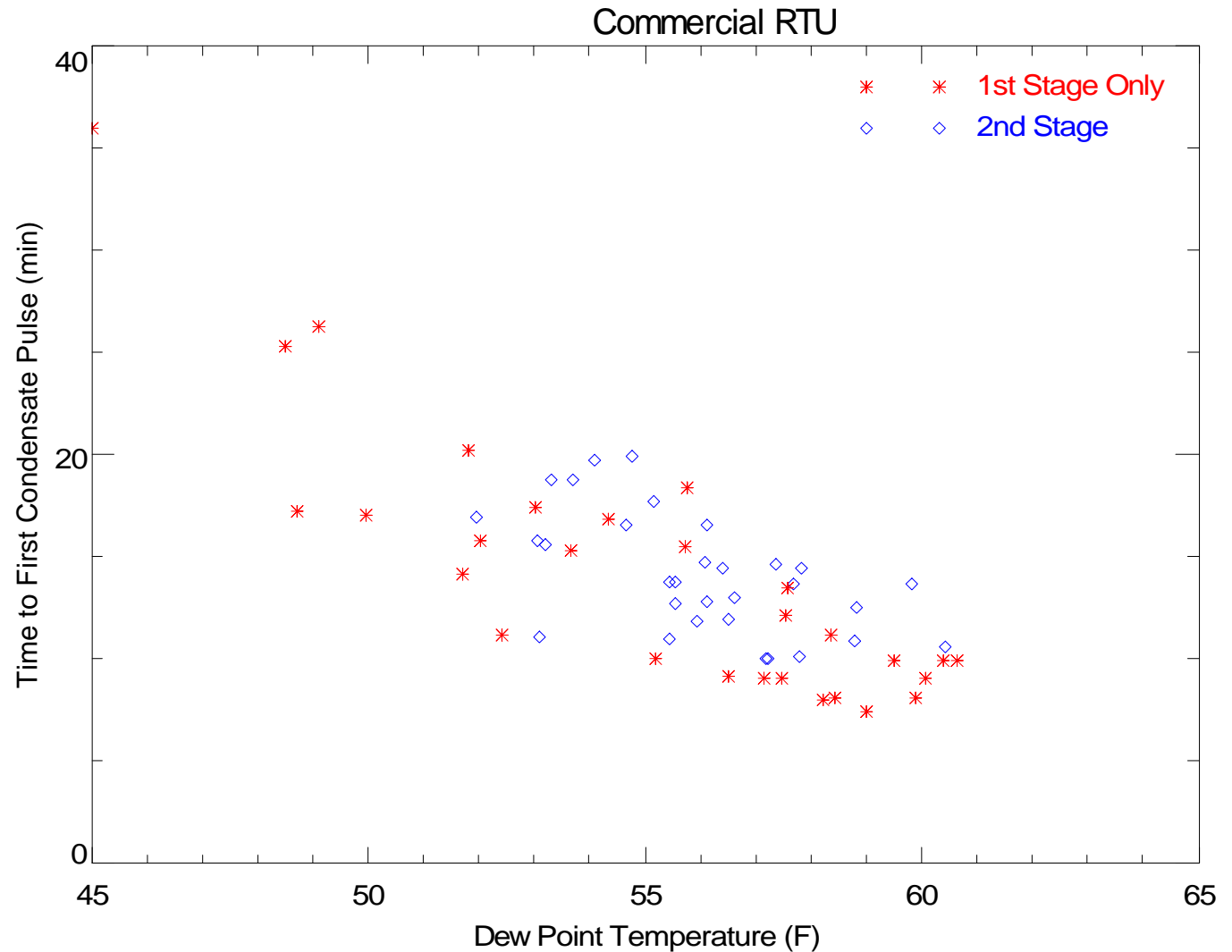

Lab + Field: Retained Moisture

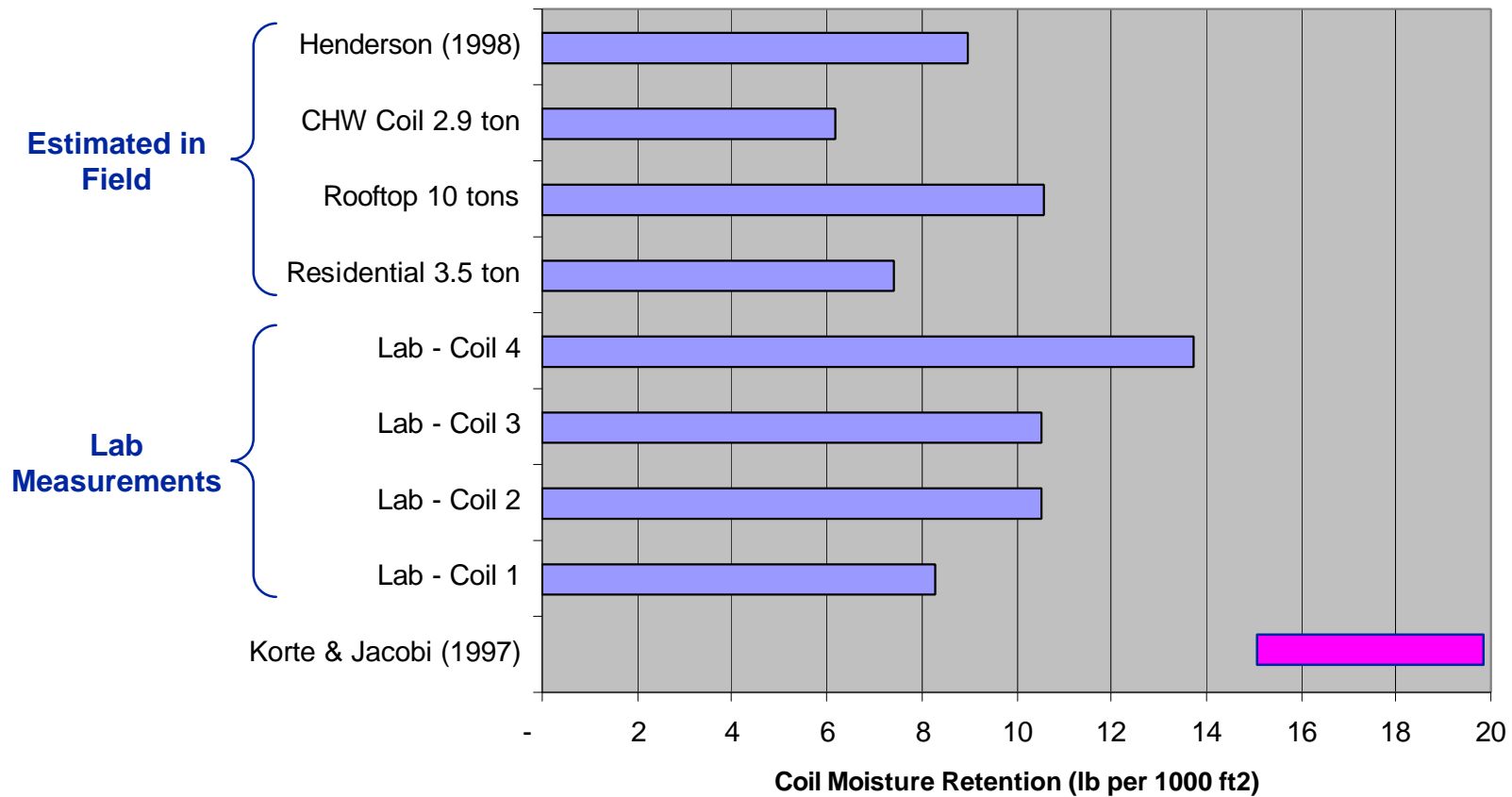

Moisture per total gross fin area
(gross area = face area x depth x fin spacing x 2)

Lab + Field: Range of Delay Times

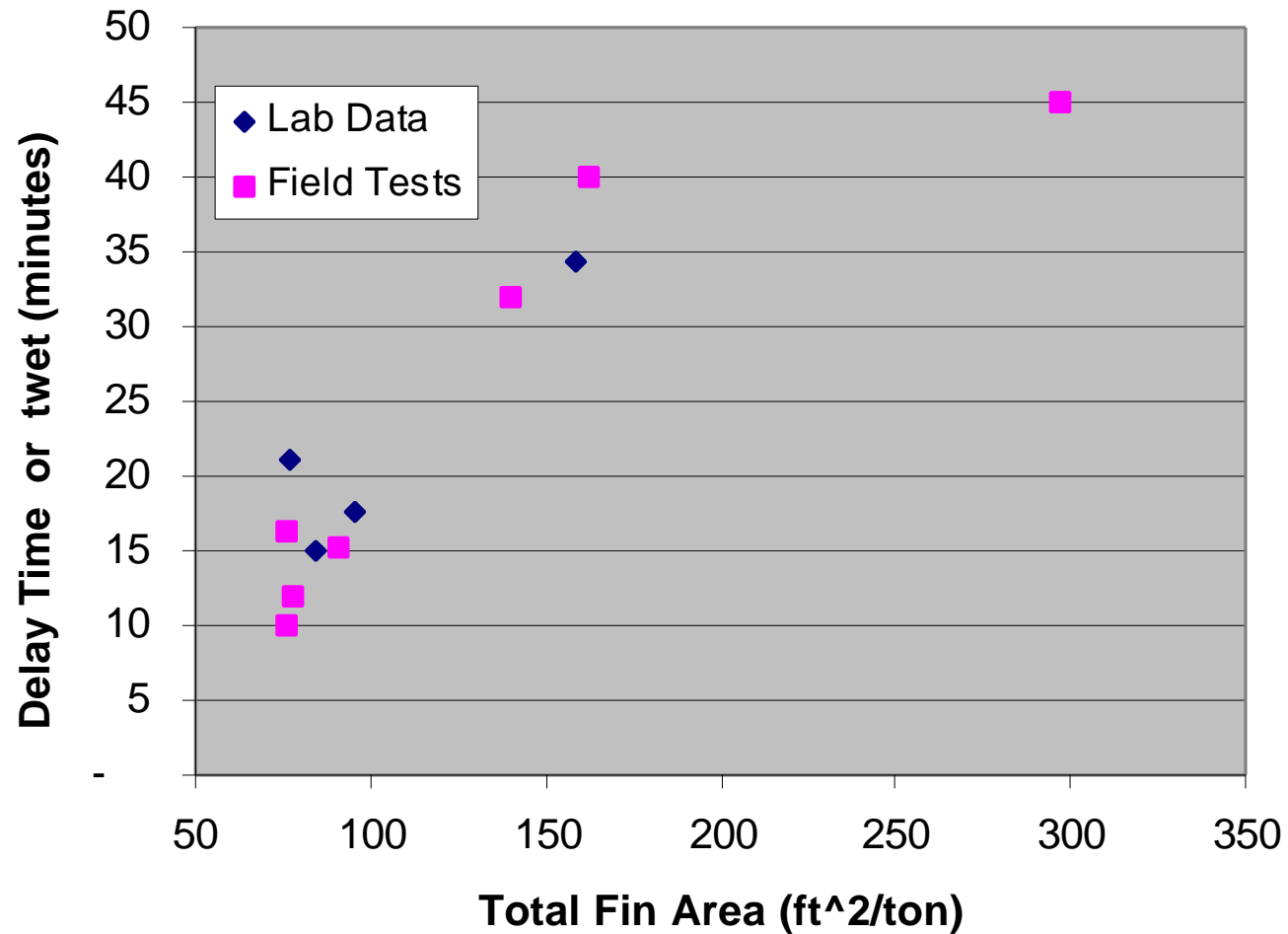

Summary

- ❑ Project due to end Sept 2003 (extension to early 2004)
- ❑ Complete lab testing of 4 more coils
- ❑ Complete field measurements at 3 remaining sites
- ❑ More data analysis (individual tests and overall trends)
- ❑ Refine latent degradation model, extend to other configurations: AUTO fan, staged coils, CHW
- ❑ These results will be published at the upcoming ASHRAE Meeting in Edinburgh, Scotland (Sept 2003)
- ❑ Final project results will be presented at future ASHRAE conferences
- ❑ Future work would be to gather more laboratory data on different coil configurations, and work with manufacturers to devise and evaluate solutions

Questions?

