

# Measured Performance Data from a Supermarket Combined Heat and Power System

EQS Symposium

Session 5: Energy and Efficiency

October 28, 2003

Hugh I Henderson, Jr. P.E.

CDH Energy Corp.



[www.cdhenergy.com](http://www.cdhenergy.com)

# Approach & Goals

- Field test to demonstrate CHP technology in a commercially “repeatable” site
  - Show what’s technically possible with current technology
  - Collect detailed data on system and building performance
    - thermal, power, and environmental impacts
- Evaluate economics at this site
  - Extend to other climates and utility rates
- Document installation and operating issues

# Project Team



## Host Facility:

- Waldbaums/A&P

## Project Sponsors:

- NYSERDA
- KeySpan Gas R&D
- Oak Ridge National Laboratory
- National Renewable Energy Laboratory

## Others:

- AGA, GTI, EPA/ETV



OAK RIDGE NATIONAL LABORATORY



# What Makes CHP Cost-Effective?

*Heat recovery makes on-site power generation practical*

Impact of Thermal Heat Utilization

It's the annual average thermal loads that matter!

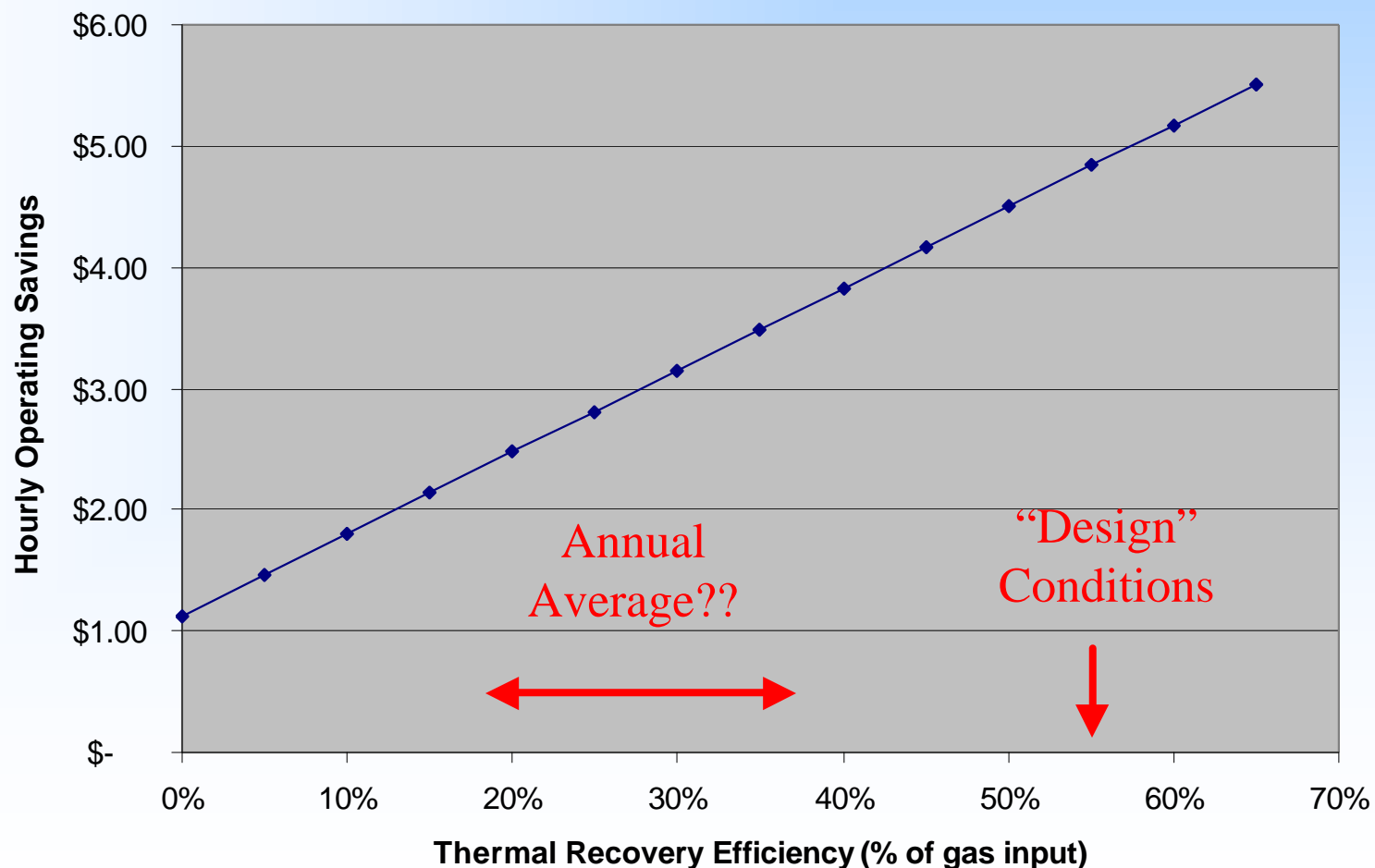

# CHP in Supermarkets

- Peak is 400-600 kW for typical store
- Significant space heating loads due to refrigerated display cases
- Desiccant dehumidification is widely used in supermarkets
  - more than 1,000 desiccant units in US stores
- Good balance between thermal and electrical loads



# The CHP System

- Capstone 60 kW Microturbine
- Nat. Gas Compressor (scroll)
- Unifin Heat Exchanger
- Hot Water Coils Installed in Munters Unit

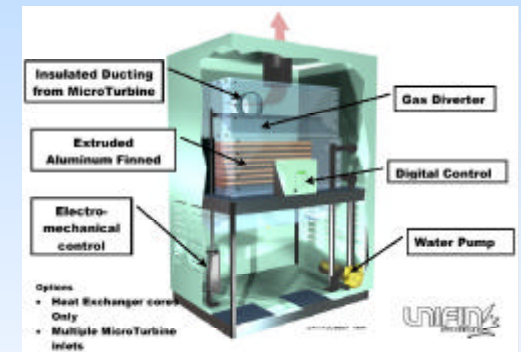

Capstone C60

# Installed CHP System



# Munters HVAC Unit

*Provides Heating, Cooling & Dehumidification*

New Coils Added

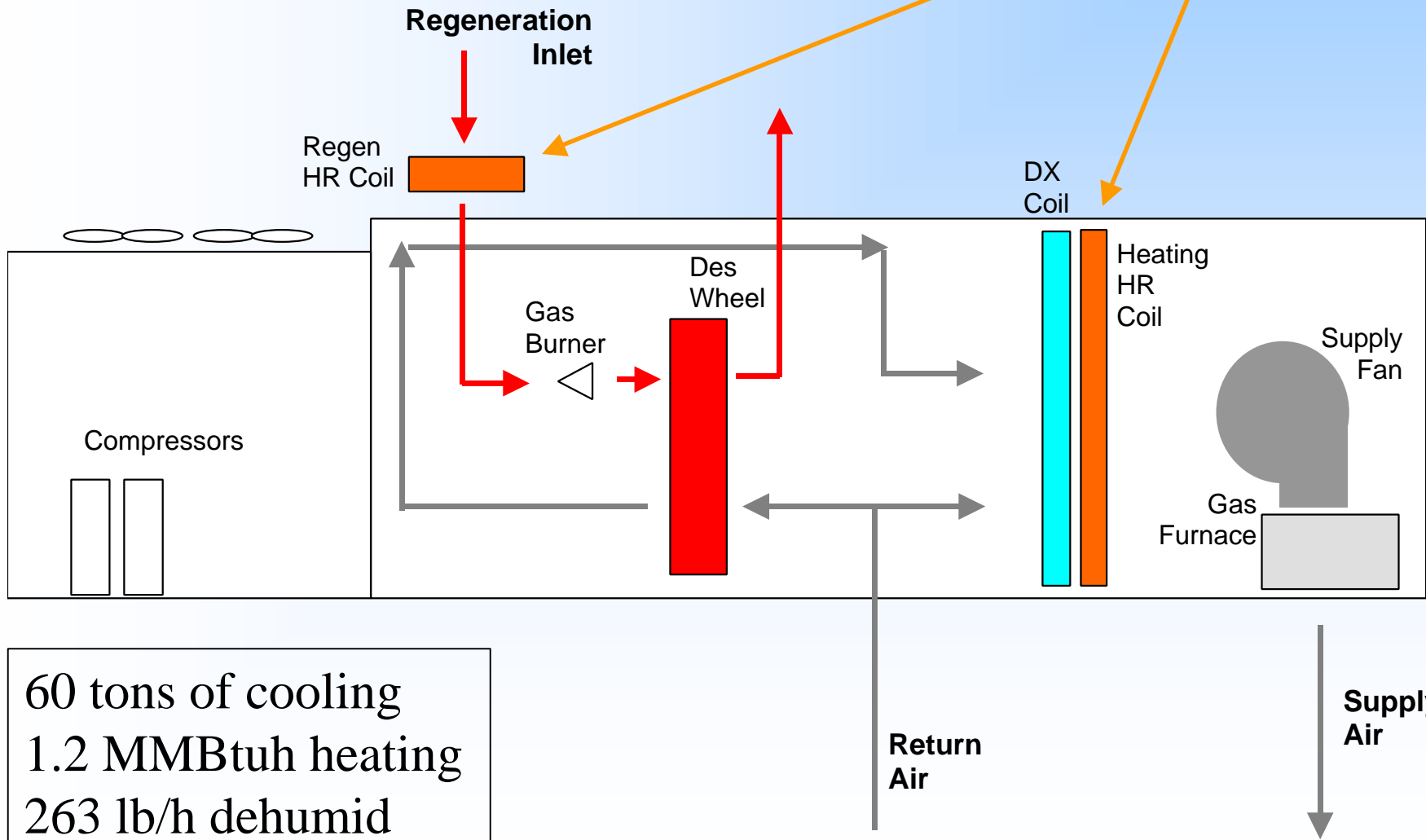

60 tons of cooling  
1.2 MMBtuh heating  
263 lb/h dehumid

# CHP System Summary

- CHP System sized for thermal loads
  - provide 60 kW of baseload power
  - grid-parallel operation only
  - may consider scheduling turbine operation for periods when heat recovery loads are low
- System can use heat recovery when available or Munters systems: fully redundant

# Field Monitoring

- Installed data logging equipment to quantify thermal and electric performance
  - electrical turbine output (kW, amps, volts)
  - thermal output of Unifin HX (flow,  $\Delta T$ )
  - turbine exhaust (T, static P, flow)
  - desiccant/HVAC unit performance (T, RH, kW)



# CHP Monitoring Points

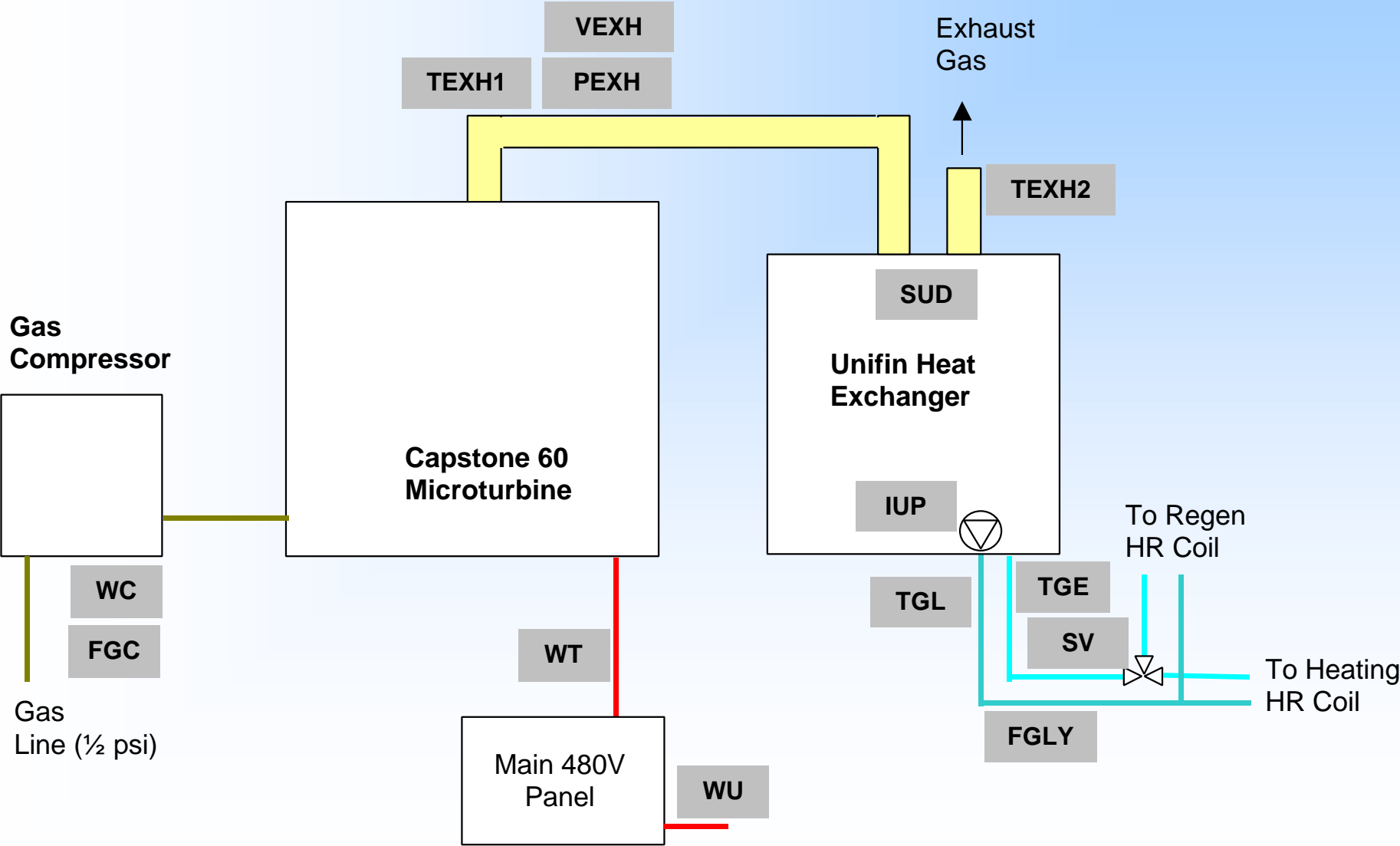

# Project History

- Equipment commissioned and instrumentation installed in August 2002
- Interconnection issue with local electric utility delayed startup until April 2003
  - non-radial electrical feed at the site required property owner to be involved
  - problem highlighted issues about interconnection in commercial tenant/owner properties

# Turbine Impact on Store Demand

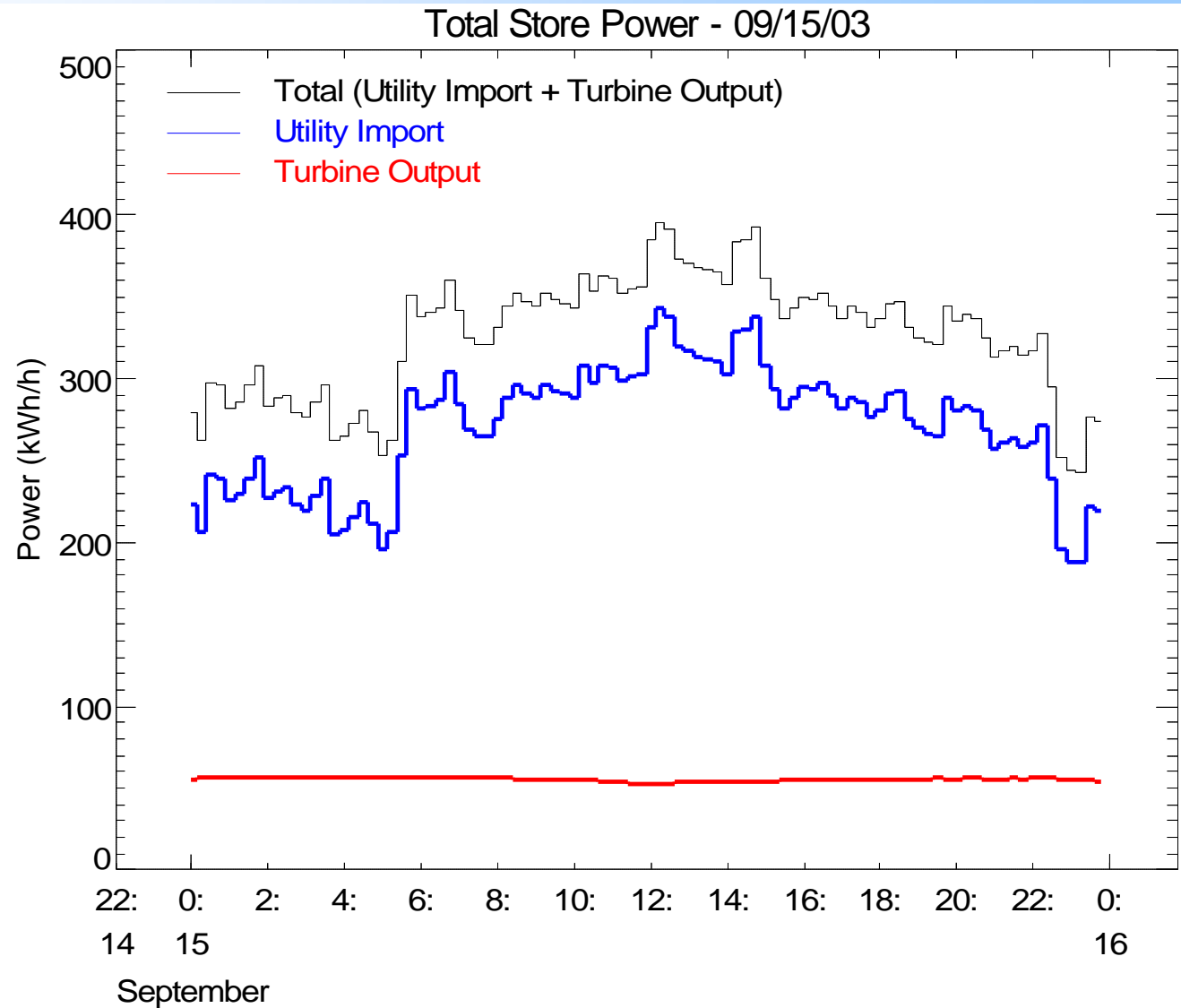

Peak Total Demand: 395.5 kW @ 12:15 PM

Peak Utility Import Demand: 342.5 kW @ 12:15 PM

# Turbine Efficiency Trend

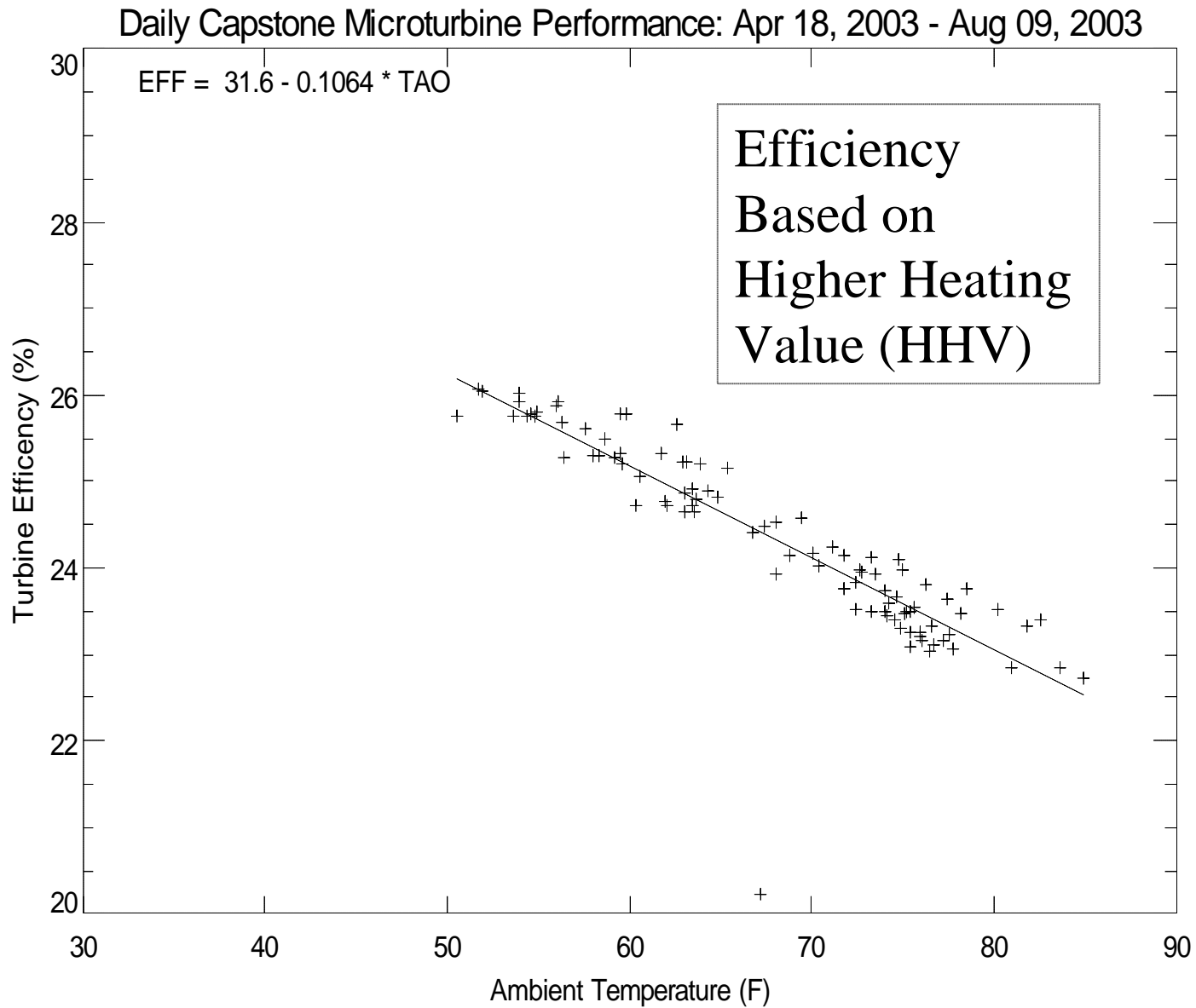

# Typical Performance of Heat Recovery System

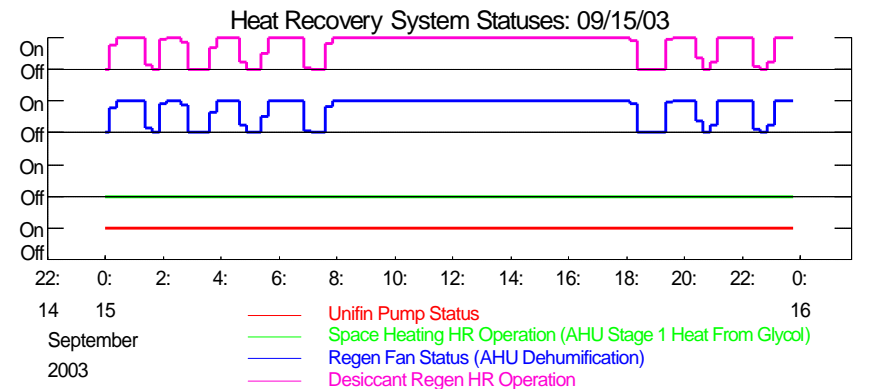
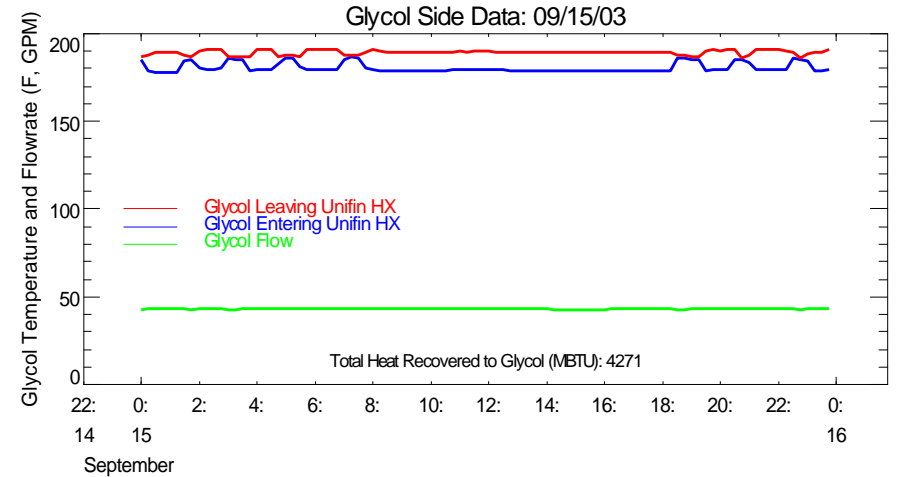
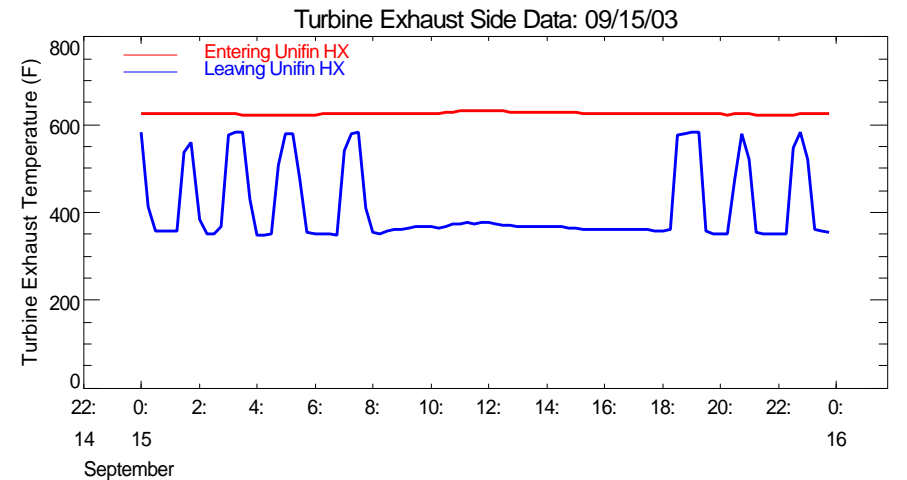

# HR Rate in Different Modes

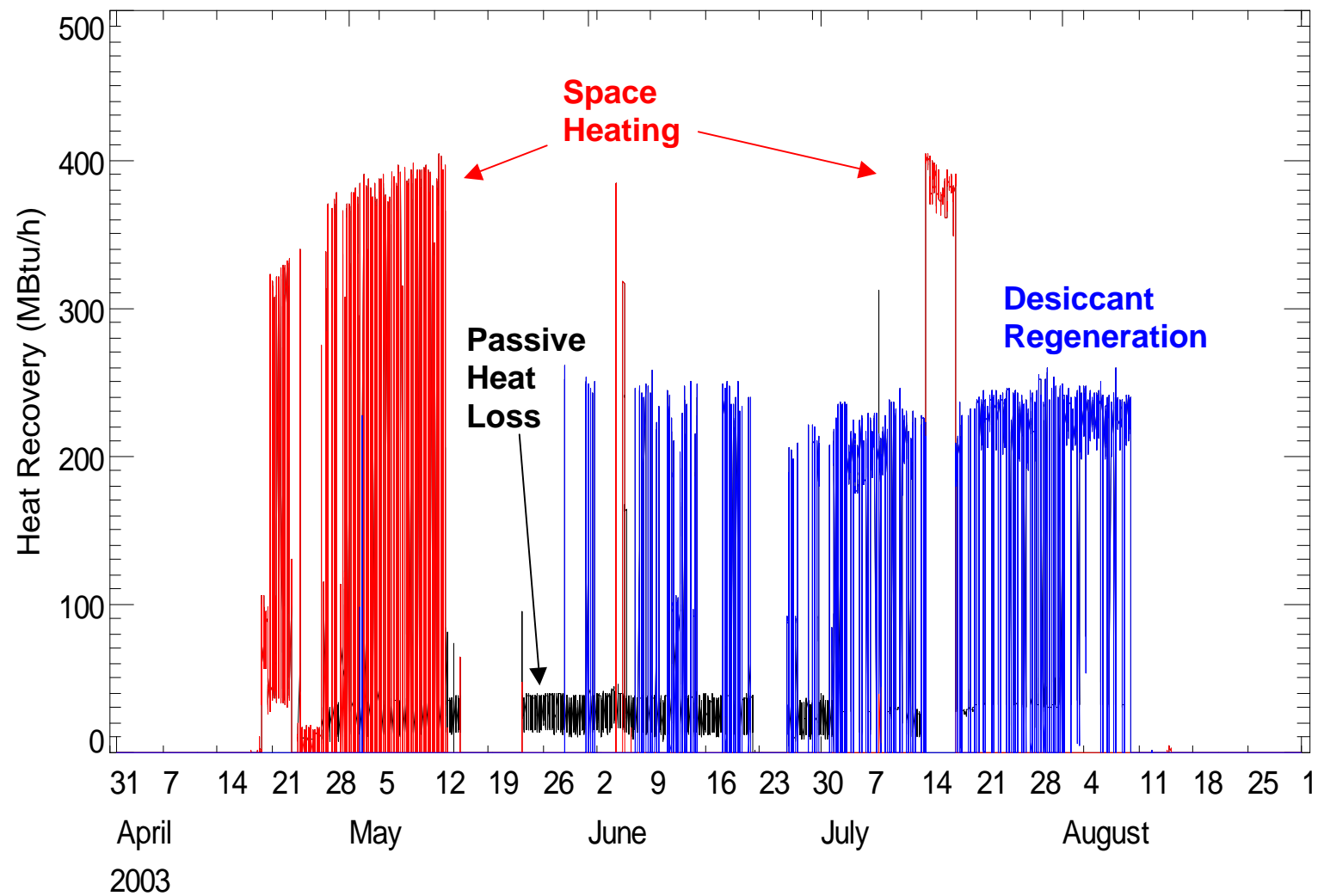

# Overall CHP Performance

Date	Turbine		Parasitic Loads		Heat Recovered	
	Power Output (kWh)	Gas Input (MBTU)	Gas Compressor (kWh)	Heat Recovery Glycol Pump (kWh)	Space Heating (MBTU)	Desiccant Regen (MBTU)
April-03	15,356	209,649	1,097.3	250.0	16,162	0
May-03	30,414	411,031	2,113.0	474.6	29,084	2,045
June-03	39,087	549,741	2,767.1	530.1	18	17,223
July-03	39,185	568,723	2,878.3	635.8	103	72,102
August-03	10,864	161,883	838.9	185.7	0	46,035
<b>Totals</b>	<b>124,042</b>	<b>1,739,144</b>	<b>8,856</b>	<b>1,890</b>	<b>45,367</b>	<b>91,371</b>

[1-3-4+5+6] / [2]

"Net" Turbine Generation Efficiency (%)	"Net" CHP Efficiency (%)
23.2%	30.5%
23.5%	30.7%
22.5%	25.4%
21.8%	34.1%
21.1%	49.2%
<b>22.6%</b>	<b>30.1%</b>

Note: Actual natural gas HHV is used.

# Daily Summertime CHP Performance

Date	Turbine		Parasitic Loads		Heat Recovered	
	Power Output (kWh)	Gas Input (MBTU)	Gas Compressor (kWh)	Heat Recovery Glycol Pump (kWh)	Space Heating (MBTU)	Desiccant Regen (MBTU)
Aug 1, 2003	1,265.9	18,428	92.9	20.6	0	4,868
Aug 2, 2003	1,221.1	18,025	93.1	20.6	0	5,310
Aug 3, 2003	1,223.8	18,025	93.2	20.6	0	5,308
Aug 4, 2003	1,220.1	17,925	93.0	20.5	0	5,358
Aug 5, 2003	1,222.1	17,937	92.7	20.6	0	5,434
Aug 6, 2003	1,210.8	17,836	92.8	20.6	0	4,791
Aug 7, 2003	1,205.5	17,735	92.8	20.6	0	4,649
Aug 8, 2003	1,213.4	17,936	92.8	20.6	0	5,193
Aug 9, 2003	1,222.1	17,936	93.0	20.5	0	5,083
Aug 10, 2003	22.5	100	1.8	0.4	0	39
<b>Totals</b>	<b>10,864</b>	<b>161,883</b>	<b>839</b>	<b>186</b>	<b>0</b>	<b>46,035</b>

[1-3-4+5+6] / [2]

"Net" Turbine Generation Efficiency (%)	"Net" CHP Efficiency (%)
21.7%	47.8%
21.4%	50.4%
21.4%	50.5%
21.5%	51.0%
21.5%	51.4%
21.4%	47.9%
21.4%	47.2%
21.3%	49.9%
21.5%	49.4%
<b>21.1%</b>	<b>49.2%</b>

Note: Actual natural gas HHV is used.

# Impact of Heat Recovery on Desiccant Gas Use

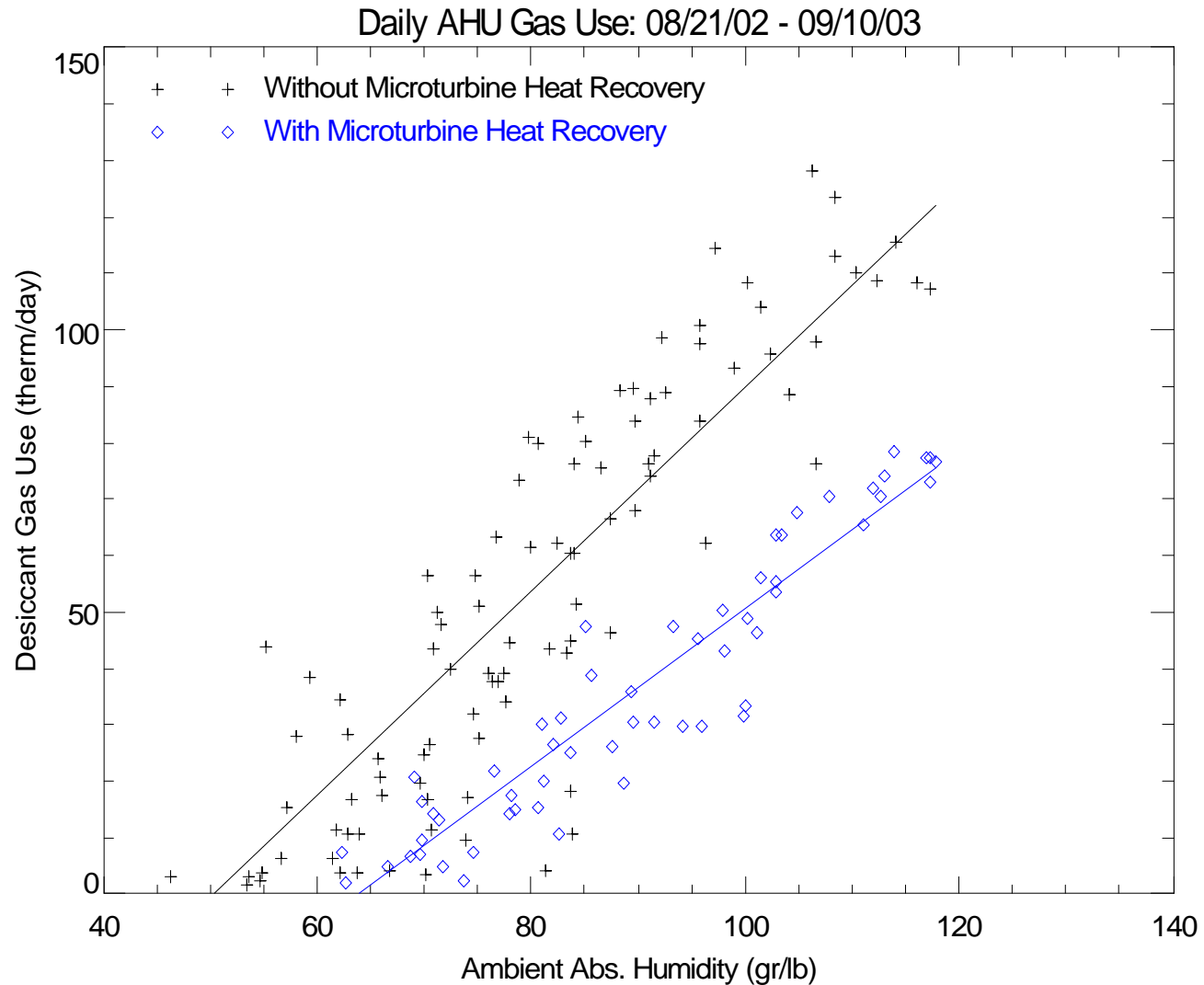

# HR Impact on Space Heating

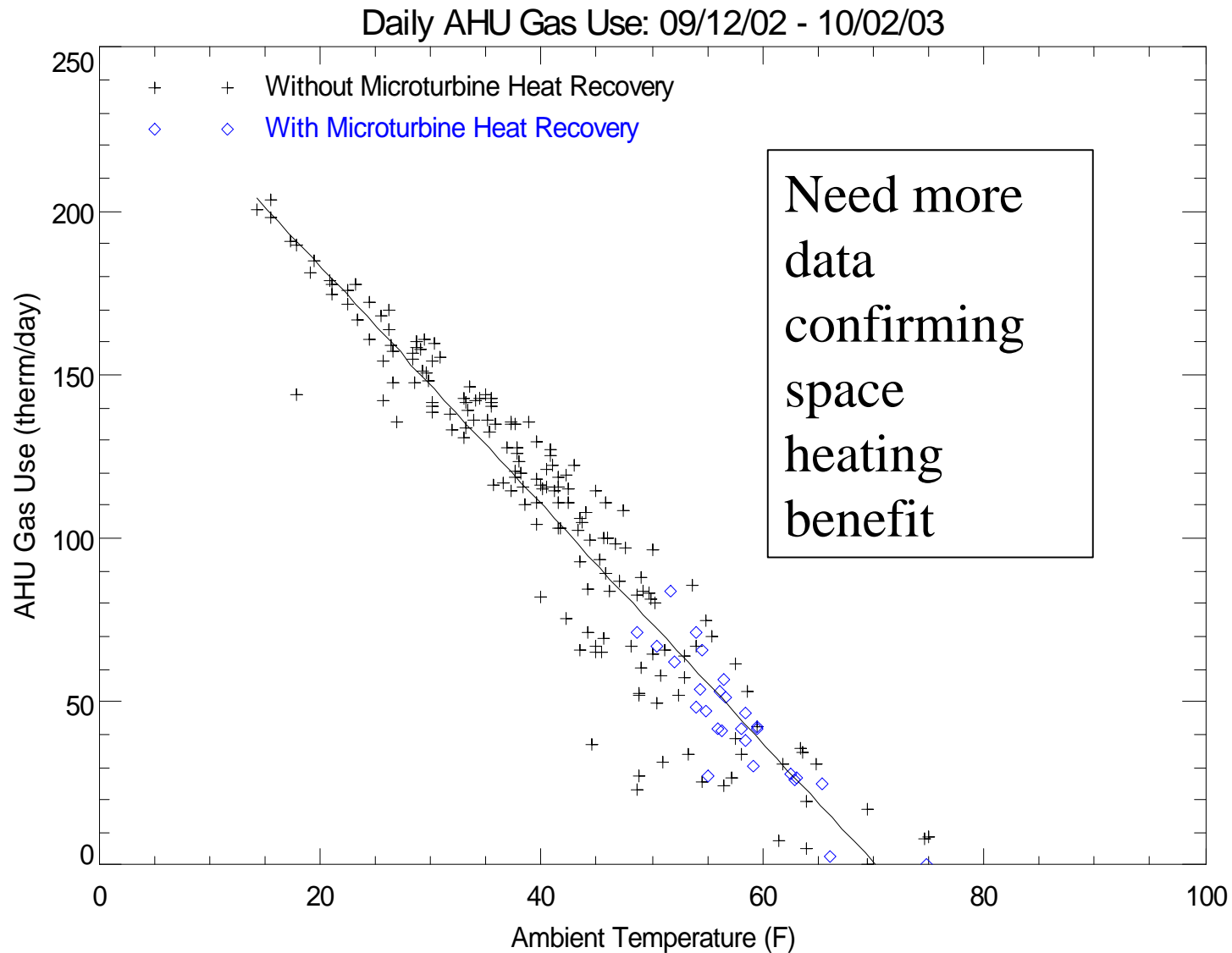

# ETV Emissions Testing



- NYSERDA funded Environmental Technology Verification (ETV) testing at this site
- High-precision testing in June 03 confirmed our thermal and power measurements
- Also collected emissions data:

	Capstone Rated Performance	Measured Performance
Nitrogen Oxides - NO <sub>x</sub> (ppmv @ 15% O <sub>2</sub> )	< 9	3.1
Carbon Monoxide - CO (ppmv @ 15% O <sub>2</sub> )	< 40	3.7
Total Hydrocarbons - THC (ppmv @ 15% O <sub>2</sub> )	< 9	0.9

# Next Steps

- Continue system monitoring through heating season
- Evaluate system economics based on measured data
  - Extend to other climates & utility rates
- Quantify environmental benefits of system compared to base building

# More Information

- CDH Monitoring & Monthly Reports:

[www.cdhenergy.com](http://www.cdhenergy.com)

(Online data access – Waldbaums)

(user/pass: waldbaums/microturbine)

- ETV Report

[www.epa.gov/etv/verifications/vcenter3-3.html](http://www.epa.gov/etv/verifications/vcenter3-3.html)

(sep 03 report)